

**NOTE: It is my policy to give a failing grade in the course to any student who either gives or receives aid on any exam or quiz.**

**INSTRUCTIONS:**

- **Be sure your name is Perfect Student!**
- **Be sure the Exam ID on your answer sheet is 10104.**
- **Answer multiple choice questions on your answer sheet. Answer other questions on the backs of the exam sheets. Be sure to indicate the question number next to the answers on the exam sheets.**

- (100 Points if wrong!) What name is pre-printed on your answer sheet, and what is your name?
  - Perfect Student, and that's my name.
  - There are no other choices! See Dr. Vickery if "A" is not true.
- (5 Points) Computer A takes 250 seconds to execute a program, and computer B takes 100 seconds to execute the same program. Which one of the following statements is true?
  - A is 2.5 times faster than B.
  - B is 2.5 times faster than A.
  - A is 250% faster than B.
  - B is 250% faster than A.
  - Which one is faster depends on the clock speeds.
- (5 Points) Which of the following statements are equivalent?
  - 1.5 times faster is the same as 250% faster.
  - 1.5 times faster is the same as 150% faster.
  - 1.5 times faster is the same as 50% faster.
  - If X is 50% faster than Y, Y is 50% slower than X.
  - If X is 1.5 times faster than Y, Y is 1.5 times faster than X.
- (5 Points) If computer A in Question 2 executed 5 billion instructions when running the program, what was its execution rate?
  - $0.5 * 10^9$  ips
  - $0.2 * 10^9$  ips
  - $0.5 * 10^8$  ips
  - $0.2 * 10^8$  ips
  - $0.25 * 10^7$  ips
- (5 Points) A processor with a 2 GHz clock has an instruction set with three classes of instructions. Class A instructions require 2 clock cycles to execute and occur 40% of the time. Class B instructions require 3 clock cycles to execute and occur 10% of the time. Class C instructions require 4 clock cycles to execute and occur 50% of the time. What is the average cpi for this processor?
  - 3.1
  - 3.2
  - 3.3
  - 3.4
  - 3.5
- (5 Points) How long would it take the processor in Question 5 to execute 250 million instructions?
  - 387.5 minutes
  - 387.5 seconds
  - 387.5 milliseconds
  - 387.5 microseconds
  - 387.5 nanoseconds

7. (5 Points) Assume each gate in the following circuit has a propagation delay of 1 nsec. What is the maximum rate at which the keypad could be changed that would allow enough time for the LED to show the proper result for each change? (The LED and keypad have no propagation delays themselves.)

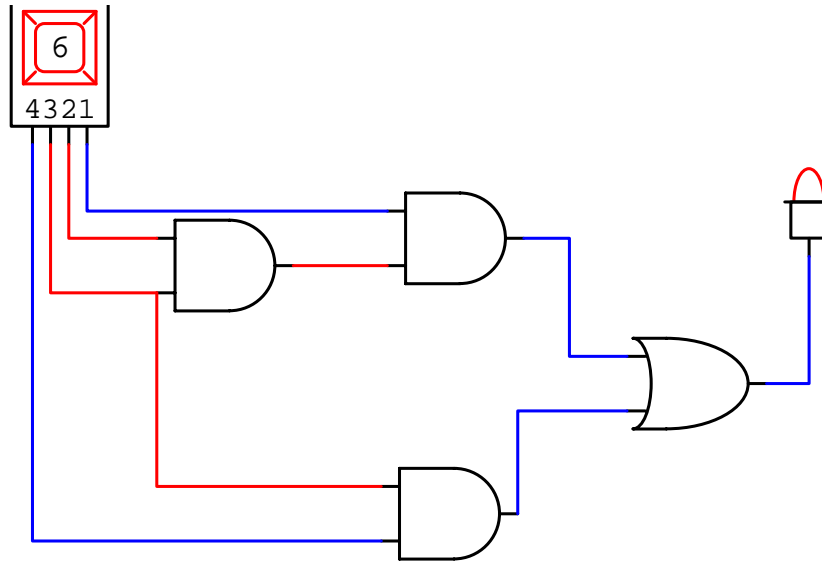

- A. 3.3 GHz  
B. 2.5 GHz  
C. 333 MHz  
D. 250 MHz  
E. 4 nsec
8. (5 Points) What is the difference between a latch and a flip-flop?
- A. "Latch" has 4 letters, but "flip-flop" has 8 letters and a hyphen.  
B. Latches have a clock input but flip-flops don't.  
C. Latches have a  $\sim Q$  output but flip-flops don't.  
D. Latches can change state any number of times during a clock pulse, but flip-flops will never change state more than once per clock pulse.  
E. Latches will never change state more than once per clock pulse, but flip-flops can change state any number of times during a clock pulse.
9. (5 Points) What is the weight of the left-most bit of an  $n$ -bit two's complement number?
- A. 1  
B.  $n$   
C.  $2^n$   
D.  $-2^n$   
E.  $-2^{n-1}$
10. (5 Points) Which of the following is the best definition of overflow?
- A. When the sum is negative.  
B. When the sum is negative and either operand is positive.  
C. When there is a carry.  
D. When there is a carry and one operand is positive and the other operand is negative.  
E. When the correct result can't be represented in the number of bits available.

11. (5 Points) What is the binary sum of the decimal values  $10_{10}$  and  $-60_{10}$  when doing 8-bit two's complement arithmetic?
  - A.  $0111\ 1111_2$
  - B.  $1010\ 0001_2$
  - C.  $1011\ 1100_2$
  - D.  $1100\ 1110_2$
  - E.  $1101\ 0100_2$
12. (10 Points) On the back of one of your exam sheets, draw a logic diagram (gates and wires) showing the right-most bit of the MIPS ALU. You don't have to draw the gates for the multiplexer or the full adder; you can just use blocks for those, but label them "mux" and "fa". Indicate where the *Less* input comes from on your diagram in words (put "from ..." next to the input wire). *Help:* The inputs are *Less*, *A<sub>0</sub>*, *B<sub>0</sub>*, *C<sub>0</sub>*, *Ainvert*, *Binvert*, and *Operation*. Mark the number of this question (12) next to your answer. Label all inputs and outputs clearly.
13. (5 Points) On the back of one of your exam sheets, draw a diagram that shows how to construct a positive edge triggered master-slave flip-flop. Mark the number of this question (13) next to your answer. Be sure to label all inputs and outputs with the usual names.
14. (10 Points) On the back of one of your exam sheets, draw a timing diagram for a D flip-flop. Show 4 clock pulses. Assume the flip-flop is initially 1, and draw the diagram so that the D input has the values 0, 1, 0, 1 during the four clock pulses. Be sure to show accurately when the value of Q changes throughout your diagram. Mark the number of this question (14) next to your answer.
15. (15 Points) On the back of one of your exam sheets, draw a state diagram, a state table, and a complete logic circuit for a state machine that has an input named "In" and an output named "Out." Design the machine so that Out is true for exactly one clock period each time In goes true, no matter how long In remains true. Mark the number of this question (15) next to your answer. Be sure to identify clearly what is your State Diagram, what is your State Table, and what is your Circuit Diagram.